



Twin Tec *Installation Instructions for Ignition Model 1005S EX*

CAUTION: CAREFULLY READ INSTRUCTIONS BEFORE PROCEEDING.

OVERVIEW

Twin Tec ignition Model 1005S-EX is 50 states street legal (ARB E.O. No. D-641-3 for use with the following Harley-Davidson® motorcycle models:

- All 1998-2003 XLH 883cc and 1200cc Sportster® except 1200S

The Model 1005S EX replaces the original equipment (OE) electronic ignition system. The unit mounts in the gear case cover and plugs into the OE wiring harness.

The Model 1005S EX offers adjustable advance, adjustable RPM limit settings in 100 RPM increments, and switch selectable single or dual fire modes. Single fire mode improves starting, reduces the occurrence of backfiring at low RPM, and improves power at high RPM. A red status LED flashes when the engine reaches top dead center (TDC) and allows easy static timing. The status LED also provides diagnostic information. A green VOES LED illuminates when the VOES (vacuum switch) input is active.

A special feature allows use of the tachometer wire for a PC link to a laptop computer when the engine is not running. Individual units can be programmed with a custom advance curve. The use of the tachometer wire for the PC link eliminates the need to remove the outer cover plate.

All Model 1005S EX units log engine operating data that may be downloaded and viewed with our Operating Statistics software. Model 1005S EX units also include a build-in temperature sensor and logging of temperature data.

INCLUDED PARTS

The unit includes a parts bag with an extension harness and crimp terminals that you can use to connect an optional single fire coil and a Packard Weather Pack connector set intended for installation on the tachometer wire to provide an access point for the PC link.

The Model 1005S EX must be operated with the original equipment H-D® timing rotor P/N 32402-83.

INSTALLATION

1. Turn off the ignition switch and disconnect the battery ground cable before proceeding.
2. Refer to Figure 1. Disconnect the OE ignition module. The plug is attached to the frame tube underneath the engine. You will have to disassemble the 6 pin Deutsch connector on the module side. Use needle nose pliers to pull out the secondary lock inside the connector shell. Use a small screwdriver to depress the plastic terminal latches while gently pulling out each wire. If you are not familiar with Deutsch connectors, you can find more detailed information in the H-D service manual. Save the connector shell and secondary lock.
3. Remove the gear case cover plate and mounting hardware. You may have to drill out two rivets that hold the cover. Remove the OE module and carefully pull the harness up through the exit hole.
4. Install the Model 1005S EX unit. Wrap electrical tape around the end of the protective wire harness sleeve and the terminals. This will compress the sleeve, protect the terminals, and allow you to easily feed the harness down through the exit hole. The tape will also keep the sleeve end from fraying.
5. Rotate the unit slightly counterclockwise of the final orientation shown in Figure 2 and then place it into position. Be careful to avoid damage to the black plastic Hall effect sensors on the bottom of the unit.
6. Route the wiring harness and install the mounting standoffs as shown in Figure 2. Do not fully tighten the standoffs or install the outer cover plate until after the static timing procedure.
7. Refer to the appropriate wiring diagram. Use the dual fire hookup shown in Figure 3 if you have an OE coil or other coil with two primary terminals. Use the single fire hookup in Figure 4 if you are installing an aftermarket coil with three primary terminals. Four of the terminals on the Model 1005S EX wire harness go into the 6 pin connector shell you disassembled in step 2. Pin numbers are

engraved on the back of the shell. The wire colors should match up with the mating connector on the OE harness. Insert the supplied white plastic seal into the empty position at pin 6. Reinstall the secondary lock.

Figure 1 - OE Module and Deutsch Connector



Figure 2 - Finished Installation



8. Insert the remaining two terminals (blue and brown wires) into the supplied connector shell and install the supplied secondary lock.
9. Plug the 6 pin connector back into the mating plug on the OE harness. Plug the 2 pin connector into

the mating plug on the supplied extension harness. Route the extension harness as required - up to the coil for single fire hookup or to some other convenient location. Make sure that the harness is clear of hot exhaust areas and cannot chafe against sharp edges. Secure the harness with nylon cable ties. For dual fire hookup, the blue wire is not used and should be taped up.

10. Install the supplied Weather Pack connector set on the brown tachometer wire as shown. If a tachometer is not used, seal the end of the mating plug with silicone RTV and use it as a protective cover. Use a proper Weather Pack crimping tool or solder the terminals. Pioneer-Standard (www.packard.pios.com) sells Packard crimping tool P/N 12014254. Snap-on sells a low cost tool, P/N PWC30.
11. **Single Fire Tach Hookup.** If your motorcycle had a tach before installation of the Twin Tec module, the tach was connected to the pink coil wire. When you connect the tach direct to the Twin Tec module as shown in Figure 4 for a single fire application, you must make sure that it is not still connected to the pink coil wire. Trace the wire going all the way back to the tach to avoid an inadvertent coil connection.

CAUTION: Single fire only. Failure to isolate the tach wire from the coil will cause damage to the Twin Tec module that is not covered under warranty.

12. Reconnect the battery ground cable. Complete the setup and timing procedures given on pages 3-7.
13. Reinstall the cover plate using two supplied 10-24 x 1/4" socket head screws and lock washers in place of the original rivets. You will have to tap the rivet holes on the inner plate (do this with the plate removed from the bike to avoid damaging the ignition). You can use the supplied 10-24 x 3/8" self threading screw as a tap.

NOTE: The unit is grounded by means of the gear case housing. The mounting surface must not be anodized or painted.

BANK ANGLE SENSOR

All 1998 and later Sportster® models come with a bank angle sensor. The bank angle sensor functions like a switch that normally grounds the green/white wire from the ignition module. If the motorcycle tips over, the switch opens, the ignition module is disabled, and the engine stops running. If the bank angle sensor is defective or electrical connections are broken, the engine will not start or run.

NOTE: If the engine will not start, the bank angle sensor has probably failed. Ground the green/white wire from the module. If the engine now starts, replace the failed bank angle sensor.

OPERATING MODES

A single 10 position rotary switch is used to select the operating mode. Switch settings are as follows:

- 0 Dual fire, multi-spark disabled
- 1 Dual fire, multi-spark enabled
- 2 Single fire, multi-spark disabled
- 3 Single fire, multi-spark enabled
- 4-7 Same as 0-3
- 8-9 Reserved factory settings

The engine will not run if the mode switch setting does not match the wiring hookup (i.e. you cannot select single fire mode with a dual fire coil hookup).

Advance curve families are shown in Figure 5. We recommend that you enable multi-spark. When multi-spark is enabled, a continuous series of sparks is fired from the advanced timing point until TDC. Most air-cooled engines require relatively cold spark plugs to prevent detonation under high load. Multi-spark reduces the consequent tendency for plug fouling at idle.

Switch settings 8-9 are reserved for factory programming and test. The unit will not operate with these settings.

RECOMMENDED TIMING SETTINGS

Advance curve families are shown in Figure 5. Each family has minimum and maximum curves. The advance slope switch allows you to run an advance curve in between these minimum and maximum

curves. Advance slope switch setting zero corresponds to the minimum advance curve. Switch setting 9 corresponds to the maximum advance curve. Higher switch settings result in a more aggressive curve.

Tuning a particular engine setup always requires some trial and error experimentation, but maximum power is usually obtained by using the highest advance setting possible without audible spark knock. Some recommended starting points are given below:

For engines run on normal pump gas (87-89 octane), use advance slope setting 5.

For engines run on 92 or higher octane gas, use advance slope setting 7.

If you experience spark knock, use a lower advance slope setting.

Note that the wide-open throttle (WOT) curves are active unless the VOES input is grounded. During idle and cruise, the VOES input is grounded (green VOES LED illuminated) and the low manifold pressure (MAP) curves are active.

TUNING TIP: Excessively lean air/fuel ratio (AFR) increases the tendency for spark knock. Test the motorcycle on a dyno with an exhaust gas sniffer to check AFR and make sure the carburetor is jetted to factory specifications.

RPM LIMITER SETTING

You can set the RPM limit from 3,000 to 9,900 RPM in 100 RPM increments by means of two rotary switches. The RPM limit is X100 switch setting (i.e. 57 = 5,700 RPM). Inadvertent settings below 3,000 RPM are ignored and result in a 3,000 RPM limit.

The Model 1005S EX uses a newly developed RPM limiting algorithm that has been highly optimized for odd firing V twin engines. When the engine is held against the RPM limit, cylinder firing is always paired. This eliminates a torque couple and results in very smooth operation compared to random or sequence type RPM limiters.

Set a safe RPM limit that is appropriate for your engine. Most Sportster® engines with OE valvetrain components should not be run over 5,700 RPM.

Figure 3 - Dual Fire Wiring Diagram

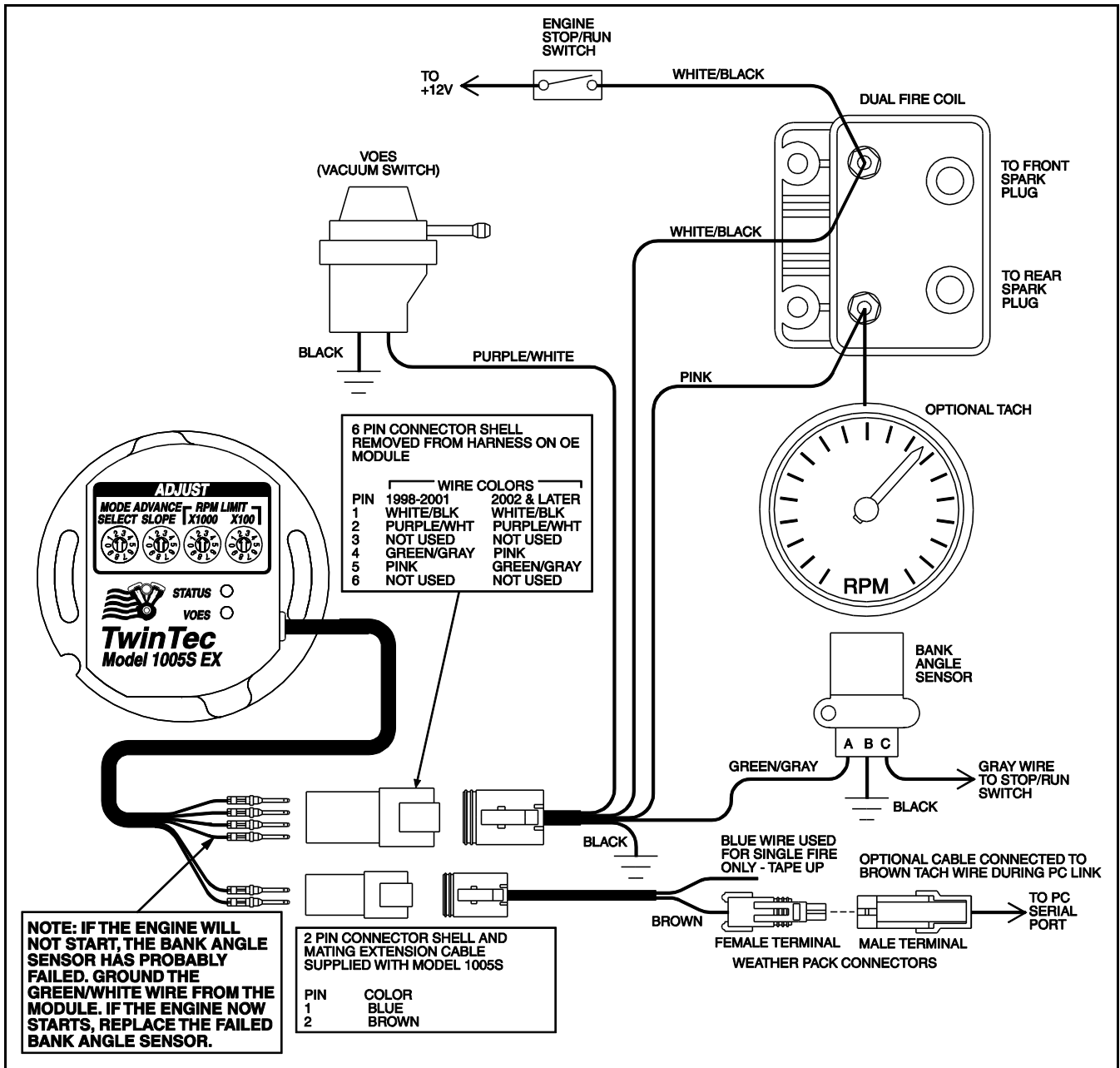

STATIC TIMING PROCEDURE

1. Timing marks are located on the flywheel and may be viewed by unscrewing the inspection hole plug. Most engines will have both TDC and advance timing marks for the front cylinder as shown in Figure 6. If you are not sure, refer to your shop manual. You can also identify the TDC mark by removing the spark plugs and rotating the crankshaft (turn rear wheel in high gear) until the front piston comes up on TDC.
2. For static timing, you must rotate the crankshaft so that the front piston is at TDC on the compression stroke. Remove spark plugs and rotate crankshaft. If you place your thumb over the spark plug hole, you will feel pressure as the piston comes up on the compression stroke. Continue rotating the crankshaft until the TDC mark is precisely centered in the inspection hole.

Figure 4 - Single Fire Wiring Diagram

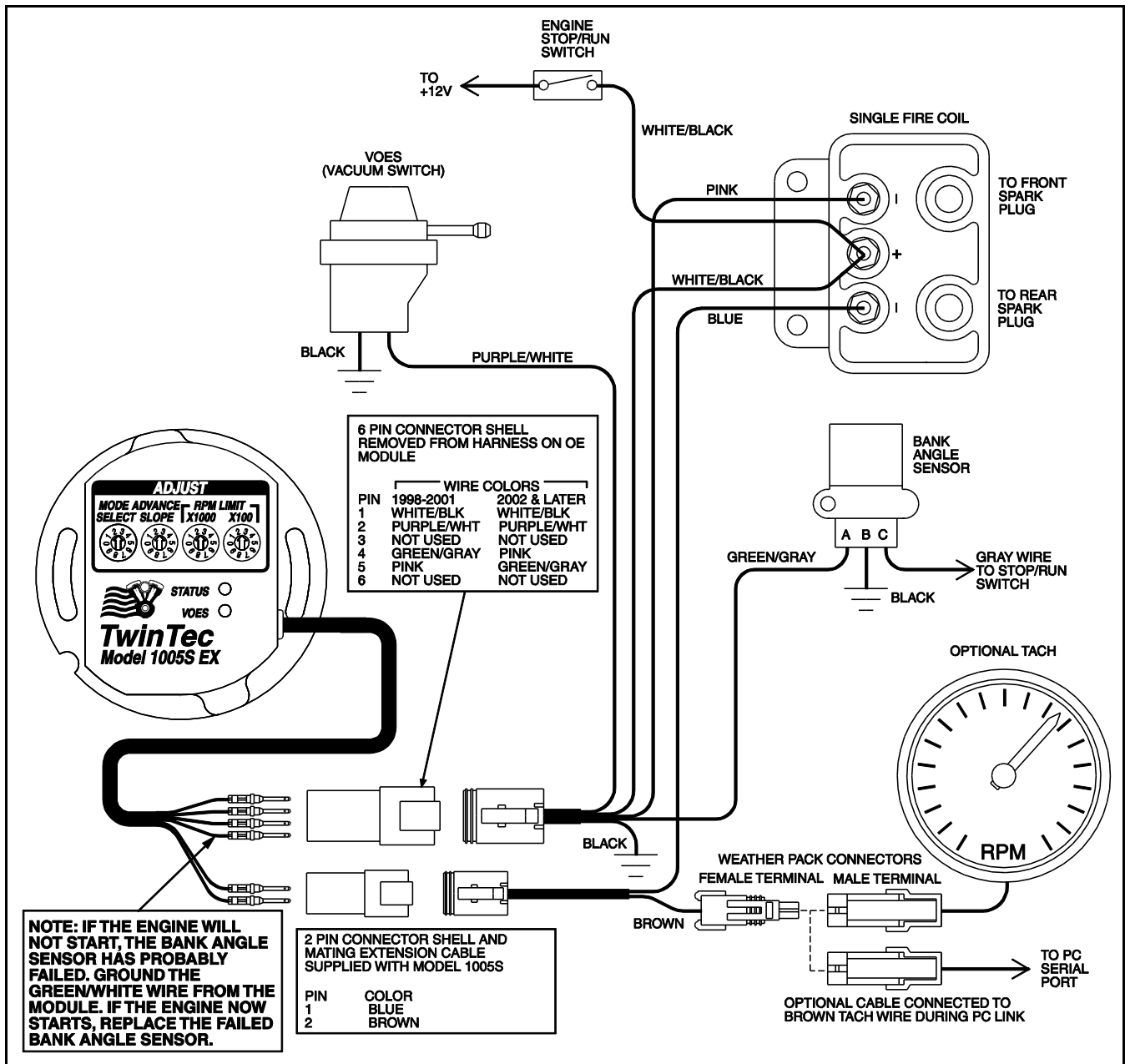

3. Ground the spark plug cables to avoid a shock hazard. You can use small jumper wires with alligator clips for this purpose.
4. Turn on the ignition switch. The red LED is used as a timing indicator. **Note that the LED does not immediately illuminate when power is first turned on.** Rotate the ignition unit back and forth until the red LED illuminates. Then slowly rotate

the unit clockwise until the LED goes out. Note that the LED goes out at TDC.

5. Tighten the standoffs to secure the unit. Turn off the ignition switch and reinstall the spark plugs.

PRECISE TIMING PROCEDURE

1. Use a standard timing light. Note that most dial-back type timing lights will not work correctly with dual fire applications. If you have a dial-back timing light, set the dial-back to zero. Do not enable multi-spark while setting timing.
2. The precise timing procedure is based on using the 20° BTDC timing mark and maximum advance curve with VOES grounded that reaches 20° BTDC between 1,000-1,500 RPM (refer to Figure 5). To use this procedure, you must have a properly functioning VOES switch connected.
3. Set mode switch to 0 for dual fire or 2 for single fire. Set advance slope switch to 9. Connect the timing light pickup to the front cylinder spark plug cable. Loosen standoffs securing the ignition unit. Run the engine at a steady speed around 1,200 RPM. Verify that the green VOES LED is illuminated. Rotate the ignition to center the 20° BTDC timing mark in the inspection hole. Tighten standoffs and verify that the timing has not changed. When done, change mode and advance slope switches back to desired values.

GENERAL RECOMMENDATIONS

Coil primary resistance must not be less than 3 ohms. Most OE style dual fire and aftermarket single fire coils meet this requirement. Coils for the new Twin Cam 88® engine have low primary resistance and are not compatible.

Due to the short lengths involved on motorcycle applications, energy losses in spark plug wires are insignificant. OE carbon core suppression cables will deteriorate after several years. For a more durable replacement, we suggest spiral core spark plug cables.

The Twin Tec module is compatible with all modern "ground sensing" type tachometers including H-D® OE and Autometer aftermarket units. The red status LED is internally connected to the tachometer output. If the red status LED blinks, the tachometer output should be functional. Some early tachometers require a high voltage trigger pulse. In this case, you will require a commercially available tachometer adapter.

CAUTION: Do not use solid copper spark plug cables or non-resistor type spark plugs. The unit may misfire.

VOES CONSIDERATIONS

The vacuum switch (VOES) provides the vacuum advance required by all street driven engines. Additional advance under low manifold pressure conditions improves idle stability and fuel economy. All 1998 and later Sportster® models are equipped with a OE VOES. Without vacuum advance at idle and part throttle, thermodynamic efficiency is reduced and engine temperatures increase significantly.

The VOES is normally open. At low manifold pressure (or manifold vacuum greater than about 5 inch-Hg), the VOES grounds the purple/white wire and causes the Twin Tec module to generate additional timing advance. The green VOES LED illuminates whenever the VOES input is active (timing advanced).

PC LINK CABLE AND SOFTWARE

The new Twin Tec USB Interface (P/N 18014) provides PC connectivity for all of our engine controls (ignition and fuel injection systems) and eliminates the requirement for multiple cables or a separate USB adapter. Two Windows based programs are available for use with the Model 1005S EX: PC Link Evo for programming custom advance curves and other engine parameters and Operating Statistics for viewing engine operating data.

PC Link Evo software will not allow you to exceed the values shown for the maximum advance curves in Figure 5 when programming custom advance curves for Model 1005S EX units.

The latest versions of our software are always available for download on our website. The software is free and will work in demo mode without a Twin Tec module attached. Refer to the software documentation for details.

The brown tachometer wire is used for the PC link. The PC link can access the Twin Tec module when the ignition is turned on and the engine has not yet been started. Once the engine is started, the brown wire resumes its normal function of driving the tachometer. Note that no damage occurs if the engine is inadvertently started while the PC link is still attached.

The optional USB interface cable connects to the brown tachometer wire as shown in Figures 4 and 5. The cable also has a ground clip that must be connected to frame or engine ground. The other end of the cable connects to the USB port on a laptop PC.

Figure 5 – Model 1005S EX Advance Curves

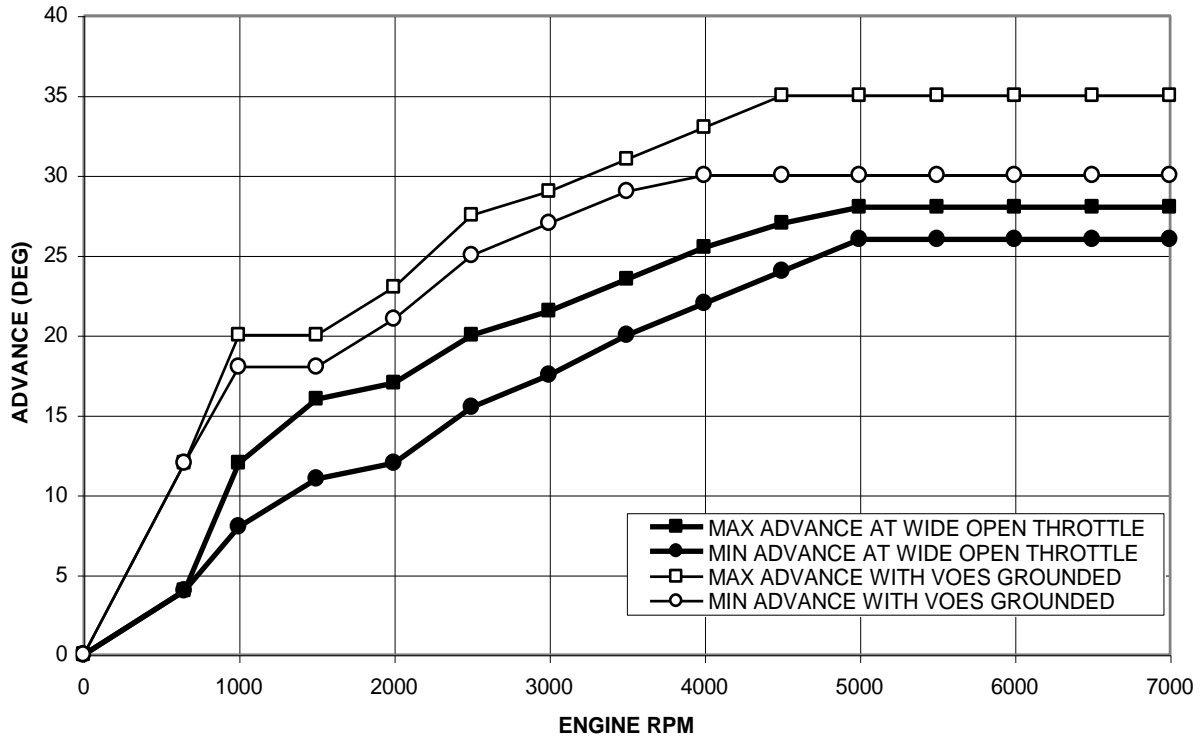
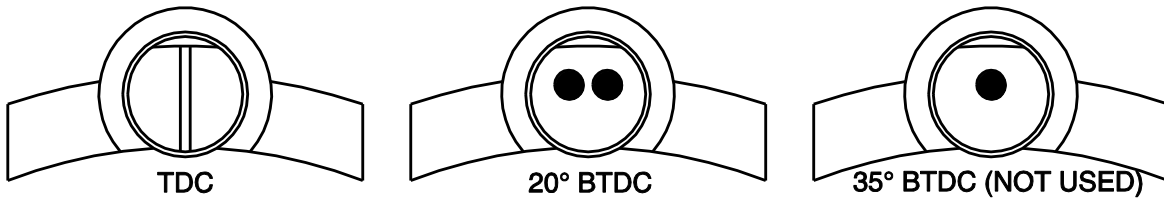

Figure 6 - Front Cylinder Timing Marks



TROUBLESHOOTING FLOWCHART

Follow the troubleshooting flowchart shown on the next page. Experience has shown that most units returned for warranty are OK and another problem, such as a defective coil, is later identified.

Troubleshooting Flowchart

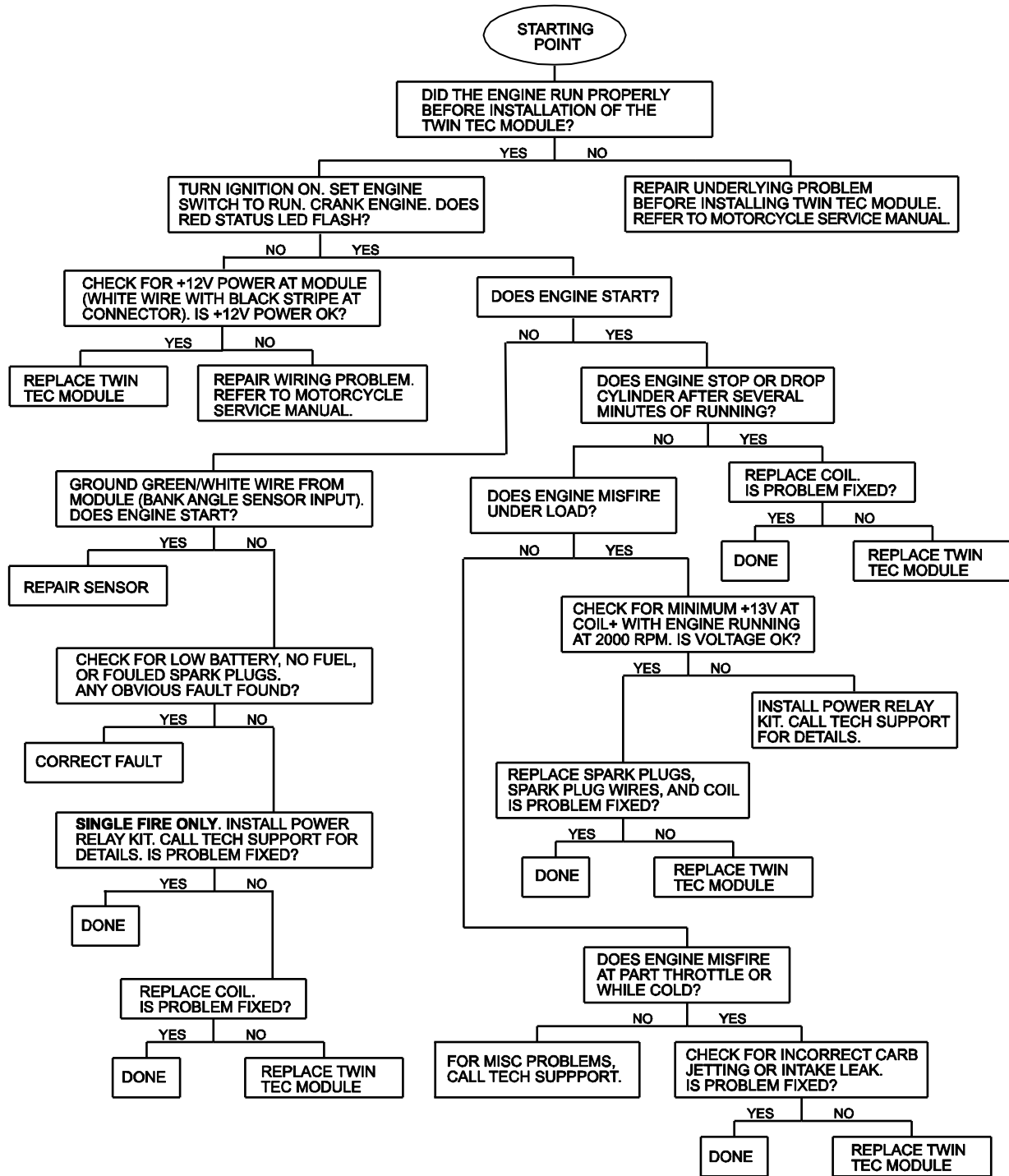

TROUBLESHOOTING TIP: *If you are installing an internal (nose cone) ignition for the first time and the engine will not start, the most likely problem is improper static timing. Make sure that the front piston is at TDC on the compression stroke and not on the exhaust stroke. Also check the bank angle sensor as described above.*