

Twin Tec *Installation Instructions for Ignition Models 1006 EX and 1007 EX*

CAUTION: CAREFULLY READ INSTRUCTIONS BEFORE PROCEEDING.

OVERVIEW

Twin Tec ignition Model 1006 EX is 50 states street legal (ARB E.O. No. D-641-1) for use with the following Harley-Davidson® motorcycles with a 7 terminal “D” style connector:

- All 1984-1994 Evolution 1340cc Big Twin
- 1986-1993 XLH 883cc and 1986-1987 XLH 1100cc Sportster®

Twin Tec ignition Model 1007 EX is 50 states street legal (ARB E.O. No. D-641-1) for use with the following Harley-Davidson® motorcycles with an 8 terminal Deutsch connector:

- All 1994-1999 Evolution 1340cc Big Twin

For installation of the Model 1006 on 1984-1990 motorcycles, you will require H-D® ignition module adapter harness P/N 32408-90. Verify that the camshaft position sensor is H-D® P/N 32400-80A and that the timing rotor is H-D® P/N 32402-83.

The Twin Tec ignition offers adjustable advance, adjustable RPM limit settings in 100 RPM increments, and switch selectable single or dual fire modes. Single fire mode improves starting, reduces the occurrence of backfiring at low RPM, and improves power at high RPM. A red status LED flashes when the engine reaches top dead center (TDC) and allows easy static timing. The status LED also provides diagnostic information. A green VOES LED illuminates when the VOES (vacuum switch) input is active.

A special feature allows use of the tachometer wire for a PC link to a laptop computer when the engine is not running. Individual units can be programmed with a custom advance curve.

INCLUDED PARTS

All units include a parts bag with Packard Weather Pack connectors for single fire coil and tachometer hookup.

INSTALLATION

1. Turn off the ignition switch and disconnect the battery ground cable before proceeding.
2. Find and remove the OE ignition module. The OE module is usually located under the seat, under a side cover, or beneath the gas tank.
3. Install the new Twin Tec module. Figure 1 shows a typical installation under the seat. You can reuse the original mounting hardware.
4. **Dual Fire.** Use this hookup if you have an OE coil or other coil with two primary terminals. Refer to Figure 2. The two Weather Pack plugs on the Twin Tec module are not used. If your motorcycle has a tachometer, it will remain connected to the coil as shown in Figure 2.
5. **Single Fire.** Use this hookup if you are installing an aftermarket single fire coil with three primary terminals. Refer to Figure 3. Run the additional blue wire to the coil as shown. If your motorcycle has a tachometer, it must be connected to the brown wire from the Twin Tec module as shown.

Figure 1 - Typical Installation



6. **Single Fire Tach Hookup.** If your motorcycle had a tach before installation of the Twin Tec module, the tach was connected to the pink coil wire. When you connect your tach direct to the Twin Tec module as shown in Figure 3 for a single fire application, you must make sure that it is not also connected to the pink coil wire. Trace the wire going all the way back to the tach to avoid an inadvertent coil connection.

CAUTION: Single fire only. Failure to isolate the tach wire from the coil will cause damage to the Twin Tec module that is not covered under warranty.

7. Route all wires along frame tubing. Make sure that the wires remain clear of hot exhaust areas and cannot chafe against sharp edges. Secure all wires with nylon cable ties.

8. **Weather Pack connector notes.** Use a proper Weather Pack crimping tool or solder the terminals. Pioneer-Standard (www.packard.pios.com) sells Packard crimping tool P/N 12014254. Snap-on sells a low cost tool, P/N PWC30. If your application does not use the two Weather Pack connectors at the Twin Tec module, seal the end of the supplied mating plugs with silicone RTV and use them as protective covers.
9. Reconnect the battery ground cable.

Figure 2 - Dual Fire Wiring Diagram

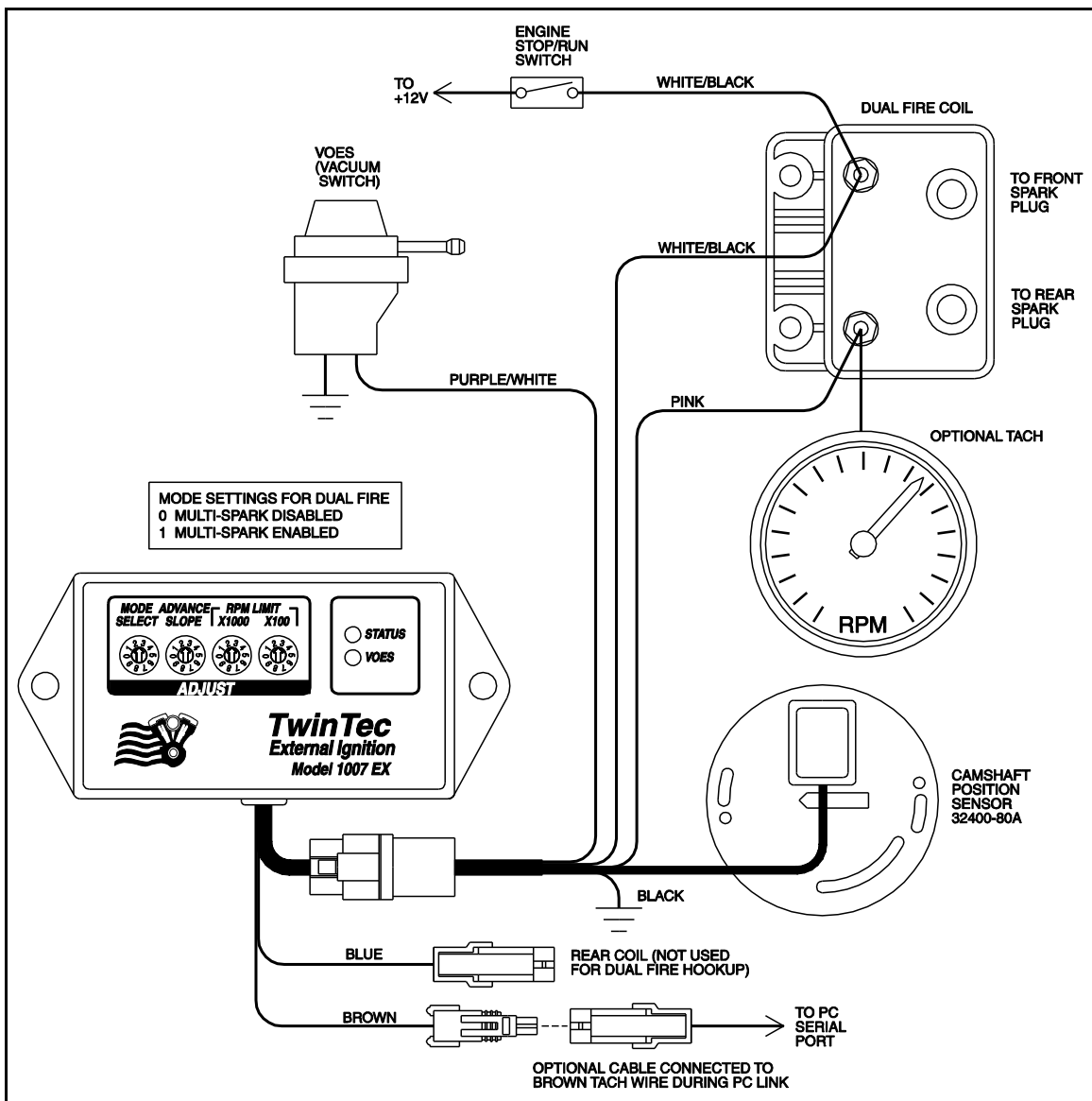
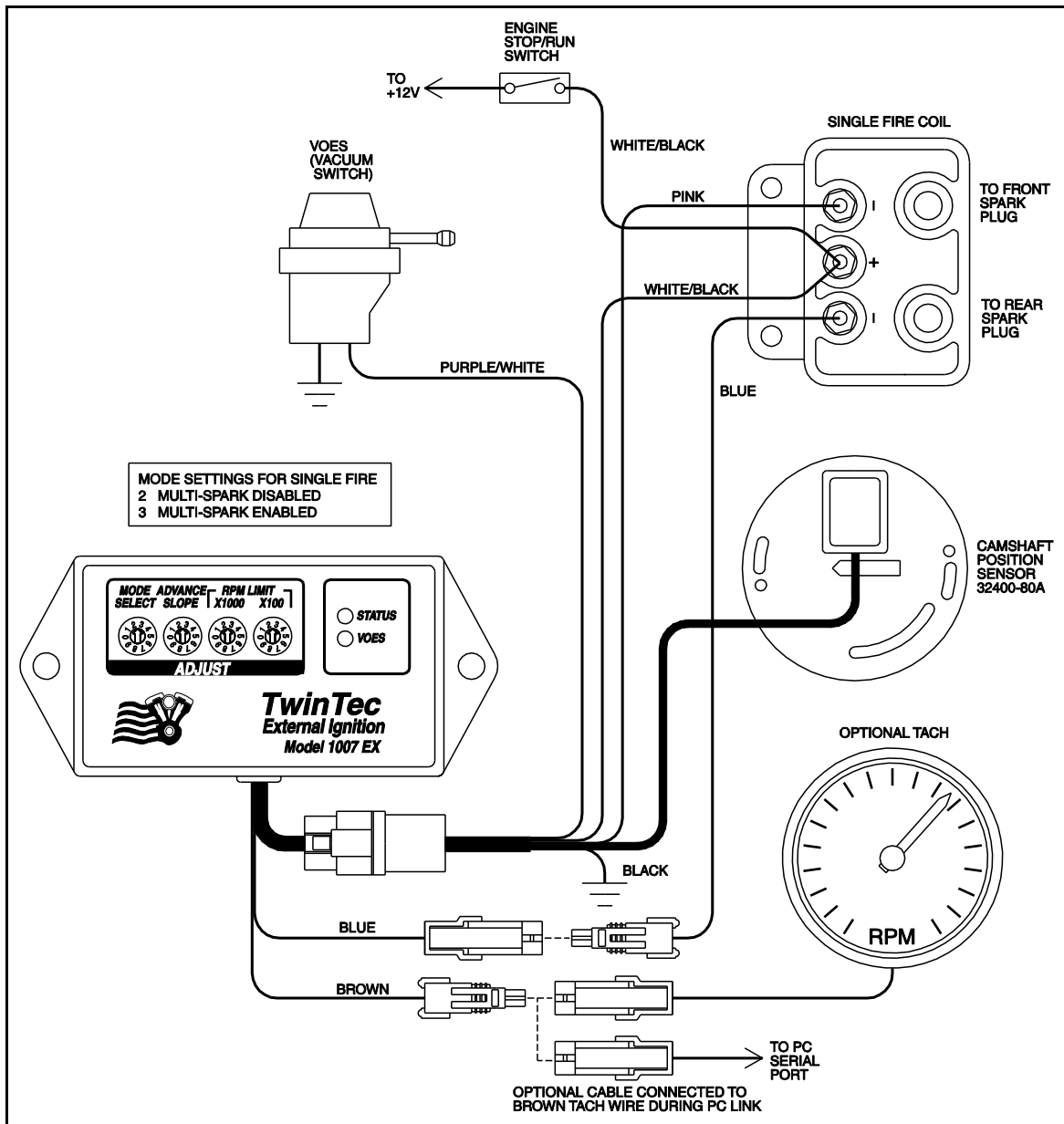

Figure 3 - Single Fire Wiring Diagram



OPERATING MODES

A single 10 position rotary switch is used to select the operating mode. Switch settings are as follows:

- 0 Dual fire, multi-spark disabled
- 1 Dual fire, multi-spark enabled

- 2 Single fire, multi-spark disabled
- 3 Single fire, multi-spark enabled
- 4-7 Same as 0-3
- 8-9 Reserved factory settings

The engine will not run if the mode switch setting does not match the wiring hookup (i.e. you cannot select single fire mode with a dual fire coil hookup).

Advance curve families are shown in Figure 4. We recommend that you enable multi-spark. When multi-spark is enabled, a continuous series of sparks is fired from the advanced timing point until TDC. Most air-cooled engines use relatively cold spark plugs to prevent detonation under high load. Multi-spark reduces the consequent tendency for plug fouling at idle.

Switch settings 8-9 are reserved for factory programming and test. The unit will not operate with these settings.

RECOMMENDED TIMING SETTINGS

Advance curve families are shown in Figure 4. Each family has minimum and maximum curves. The advance slope switch allows you to run an advance curve in between these minimum and maximum curves. Advance slope switch setting zero corresponds to the minimum advance curve. Switch setting 9 corresponds to the maximum advance curve. Higher switch settings result in a more aggressive curve.

Tuning a particular engine setup always requires some trial and error experimentation, but maximum power is usually obtained by using the highest advance setting possible without audible spark knock. Some recommended starting points are given below:

For engines run on normal pump gas (87-89 octane), use advance slope setting 5.

For engines run on 92 or higher octane gas, use advance slope setting 7.

If you experience spark knock, use a lower advance slope setting.

Note that the wide-open throttle (WOT) curves are active unless the VOES input is grounded. During idle and cruise, the VOES input is grounded (green VOES LED illuminated) and the low manifold pressure (MAP) curves are active.

TUNING TIP: Excessively lean air/fuel ratio (AFR) increases the tendency for spark knock. Test the motorcycle on a dyno with an exhaust gas sniffer to check AFR and make sure the carburetor is jetted to factory specifications.

RPM LIMITER SETTING

You can set the RPM limit from 3,000 to 9,900 RPM in 100 RPM increments by means of two rotary switches. The RPM limit is X100 switch setting (i.e. 57 = 5,700 RPM). Inadvertent settings below 3,000 RPM are ignored and result in a 3,000 RPM limit.

The Twin Tec module uses a newly developed RPM limiting algorithm that has been highly optimized for odd firing V twin engines. When the engine is held against the RPM limit, cylinder firing is always paired. This eliminates a torque couple and results in very smooth operation compared to random or sequence type RPM limiters.

Set a safe RPM limit that is appropriate for your engine. Most Evolution® engines with OE valvetrain components should not be run over 5,700 RPM.

TIMING PROCEDURE

Most applications do not require any timing adjustments and you can skip past the next two sections. In general, you only need to go through the timing procedure if you replaced the camshaft position sensor.

STATIC TIMING PROCEDURE

1. Timing marks are located on the flywheel and may be viewed by unscrewing the inspection hole plug. Most engines will have both TDC and advance timing marks for the front cylinder as shown in Figure 5. If you are not sure, refer to your shop manual. You can also identify the TDC mark by removing the spark plugs and rotating the crankshaft (turn rear wheel in high gear) until the front piston comes up on TDC.
2. For static timing, you must rotate the crankshaft so that the front piston is at TDC on the compression stroke. Remove spark plugs and rotate crankshaft. If you place your thumb over the spark plug hole, you will feel pressure as the piston comes up on the compression stroke. Continue rotating the crankshaft until the TDC mark is precisely centered in the inspection hole.
3. Ground the spark plug cables to avoid a shock hazard. You can use small jumper wires with alligator clips for this purpose.
4. Turn on the ignition switch. The red LED is used as a timing indicator. **Note that the LED does not immediately illuminate when power is first turned on.** Loosen screws securing the camshaft position sensor and rotate the sensor back and forth until the red LED illuminates. Then slowly

rotate the sensor clockwise until the LED goes out. Note that the LED goes out at TDC.

5. Tighten the camshaft position sensor screws. Turn off the ignition switch and reinstall the spark plugs.

PRECISE TIMING PROCEDURE

1. Use a standard timing light. Note that most dial-back type timing lights will not work correctly with dual fire applications. If you have a dial-back timing light, set the dial-back to zero. Do not enable multi-spark while setting timing.
2. The precise timing procedure is based on using the 35° BTDC timing mark and race maximum advance curve with VOES grounded (low manifold pressure) that reaches 35° BTDC at 2,500 RPM (refer to Figure 4). To use this procedure, you must have a properly functioning VOES switch connected.
3. Set mode switch to 0 for dual fire or 2 for single fire. Set advance slope switch to 9. Connect the timing light pickup to the front cylinder spark plug cable. Loosen standoffs securing the ignition unit. Run the engine at a steady speed just over 2,500 RPM. Rotate the ignition to center the 35° BTDC timing mark in the inspection hole. Tighten standoffs and verify that the timing has not changed. When done, change mode and advance slope switches back to desired values.

GENERAL RECOMMENDATIONS

Coil primary resistance must not be less than 3 ohms. Most OE style dual fire and aftermarket single fire coils meet this requirement. Coils for the new Twin Cam 88® engine have low primary resistance and are not compatible.

Due to the short lengths involved on motorcycle applications, energy losses in spark plug wires are insignificant. OE carbon core suppression cables will deteriorate after several years. For a more durable replacement, we suggest spiral core type spark plug cables.

CAUTION: Do not use solid copper spark plug cables or non-resistor type spark plugs. The unit may misfire.

The Twin Tec module is compatible with all modern "ground sensing" type tachometers including H-D® OE and Autometer aftermarket units. The red status LED is internally connected to the tachometer output. If the red status LED blinks, the tachometer

output should be functional. Some early tachometers require a high voltage trigger pulse. In this case, you will require a commercially available tach adapter.

VOES CONSIDERATIONS

The use of the OE vacuum switch (VOES) is required for proper operation of the Twin Tec module. The VOES provides the vacuum advance required by all street driven engines. Additional advance under low manifold pressure conditions improves idle stability and fuel economy. Without vacuum advance at idle and part throttle, thermodynamic efficiency is reduced and engine temperatures increase significantly.

The VOES is normally open. At low manifold pressure (or manifold vacuum greater than about 5 inch-Hg), the VOES grounds the purple/white wire and causes the Twin Tec module to generate additional timing advance. The green VOES LED illuminates whenever the VOES input is active (timing advanced).

PC LINK CABLE AND SOFTWARE

The new Twin Tec USB Interface (P/N 18014) provides PC connectivity for all of our engine controls (ignition and fuel injection systems) and eliminates the requirement for multiple cables or a separate USB adapter. Two Windows based programs are available for use with the Models 1006 EX and 1007 EX: PC Link Evo for programming custom advance curves and other engine parameters and Operating Statistics for viewing engine operating data.

PC Link Evo software will not allow you to exceed the values shown for the maximum advance curves in Figure 4 when programming custom advance curves for EX units.

The latest versions of our software are always available for download on our website. The software is free and will work in demo mode without a Twin Tec module attached. Refer to the software documentation for details.

The brown tachometer wire is used for the PC link. The PC link can access the Twin Tec module when the ignition is turned on and the engine has not yet been started. Once the engine is started, the brown wire resumes its normal function of driving the tachometer. Note that no damage occurs if the engine is inadvertently started while the PC link is still attached.

The optional USB interface cable connects to the brown tachometer wire as shown in Figures 2 and 3. The cable also has a ground clip that must be connected to frame or engine ground. The other end of the cable connects to the USB port on a laptop PC.

Figure 4 – Models 1006 EX and 1007 EX Advance Curves

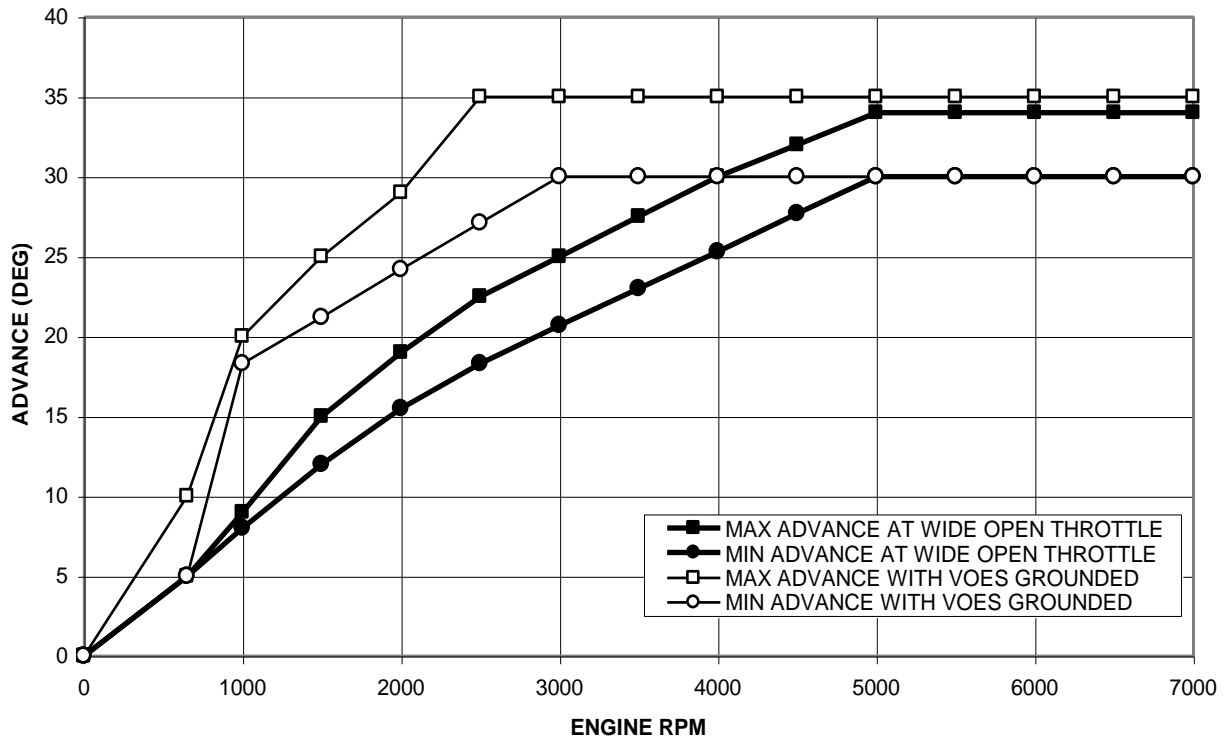
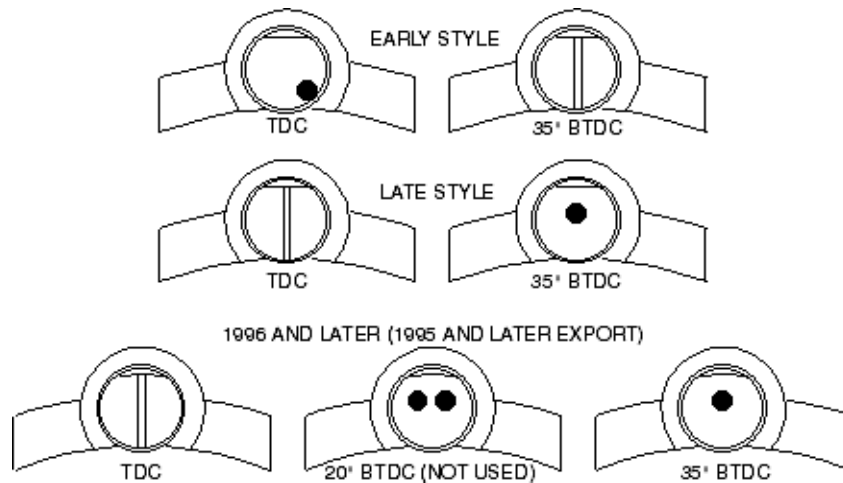

Figure 5 - Front Cylinder Timing Marks



TROUBLESHOOTING FLOWCHART

are OK and another problem, such as a defective coil, is later identified.

Follow the troubleshooting flowchart shown below.
Experience has shown that most units returned for warranty

Troubleshooting Flowchart

